

HMM 100 - 130

MOBILE HAMMER MILLS



The mobile hammer mills **HMM 100 - 130** are designed in order to obtain the **maximum yield in processing ferrous and non-ferrous metals in the heaviest uses**. They are grinding systems **installed on sliding bed**, which can be **lifted by pistons**, complete with magnetic separation and material extraction system dedicated to heavy applications: the result is a **compact grinding and selection plant**, able to satisfy the different production and space needs.

They are characterized by a reinforced solid and resistant structure, equipped with heavy hammers, for the **processing of high quantities of material** such as motors electrical, light ferrous scraps, metallic scraps (aluminium profile and carter).

They are characterized by the **wide possibility of configurations**, hydraulic handling for the main components and the quick replacement of the grids, which allow the maximum flexibility of use, a **net increase in the production capacity** and the **reduction of operating costs**.

The management is **simple and intuitive**, with programs that can be saved according to the type of material to process.

The HMM series mobile hammer mills can be **perfectly integrated in the smart factory systems 4.0**.



PROCESSED MATERIAL

Aluminium scrap treatment plant



Tins and cans from MSW treatment plant



Electric motors treatment plant



TECHNICAL DETAILS

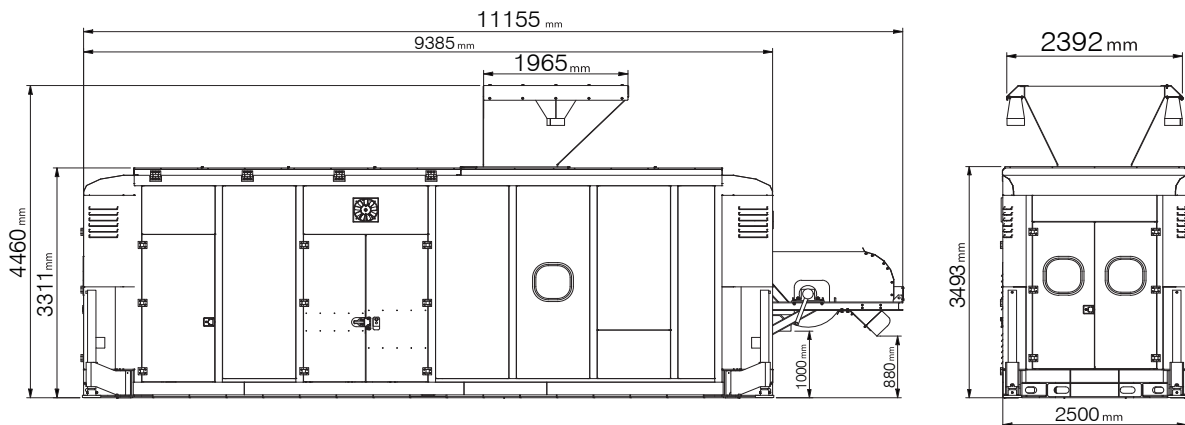

Model HMM 100

Model	Hammers No.	Cutting chamber mm	Power kW	Hourly production Tons/h*
HMM 100	24	1.000	250-315	8-10
HMM 130	32	1.300	315	12

*Hourly production can change depending on the type of processed material and the type of installed grid.



ITR Recycling Technologies
is a brand of O.M.A.R. Srl
Tel. +39 - 0422 521028
info@itrimpanti.com
www.itrimpanti.com

O.M.A.R. Srl
Via Marmolada, 2 Z.I. Nord
31027 Spresiano - TV - Italy
Tel. +39 - 0422 725890
Fax. +39 - 0422 725959
info@omar.it
www.omar.it